

Electronic Counters

From today the vacuum tube is always seen as an analog item. But it was used as an electronic switch too, which led the way to the first digital circuits. The flip-flop invented by Eccles and Jordan (also called 'Eccles-Jordan circuit' or 'binary' in former times) was the basic building block for the electronic counters launched by Berkeley Scientific and Hewlett-Packard in the early fifties. The theory of operation is described here for those interested in vintage technology. The text and the pictures are based on the description found in the manual of the CMC (Computer Measurements Company) model "111" decade counter unit (DCU).

Flip-Flop basics

Figure II-1 illustrates the circuit of a typical flip-flop. This circuit has two stable states: either stage A is conducting and stage B is cut-off, or vice versa. Assuming initially that stage A is conducting resulting in a low plate voltage. This causes a low stage B grid voltage. The plate current through stage A results in a high cathode voltage at the common cathode resistor. So stage B is non-conducting because of low grid and high cathode. Plate of stage B drives the grid of A high which stabilizes this condition.

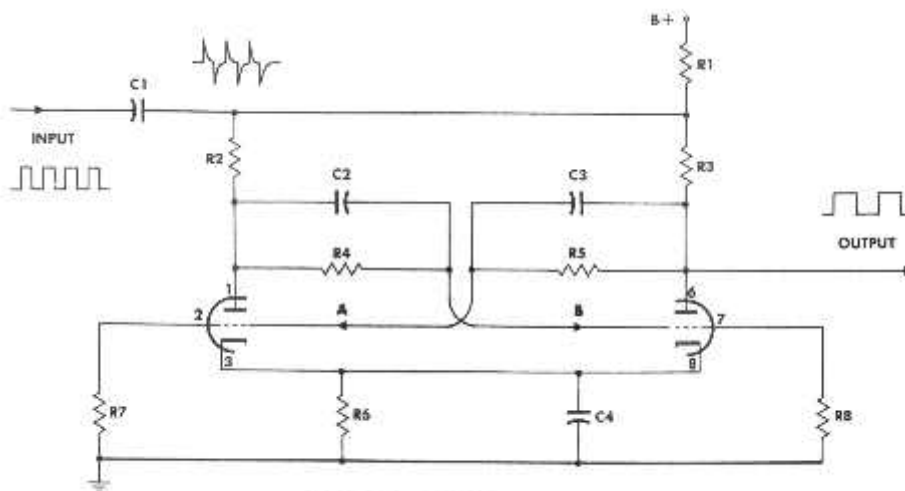

102-3

FIG. II-1 TYPICAL BINARY

If the input is driven with pulses, C1 and R1 produce positive and negative spikes at the grid of stage A. The positive spike has no effect, because grid of A is already at high potential. However the negative spike lowers the grid voltage and therefore the plate current of stage A will decrease as well as the common cathode voltage. Stage B grid becomes more positive with respect to the cathode and plate current begins to flow. The conducting stage B now holds non-conducting stage A cut-off.

The positive spike of the next pulse applied to the flip-flop will now recycle stage A conducting and stage B cut-off. The Flip-Flop produces one pulse at plate of stage B for every two input pulses. Hence it acts as a divide-by-2 scaler.

Increase the count capability

If four flip-flop's are connected in series (Figure II-2) the output pulse will be produced for every 16 input pulses. The count capability is now from '0' to '15'.

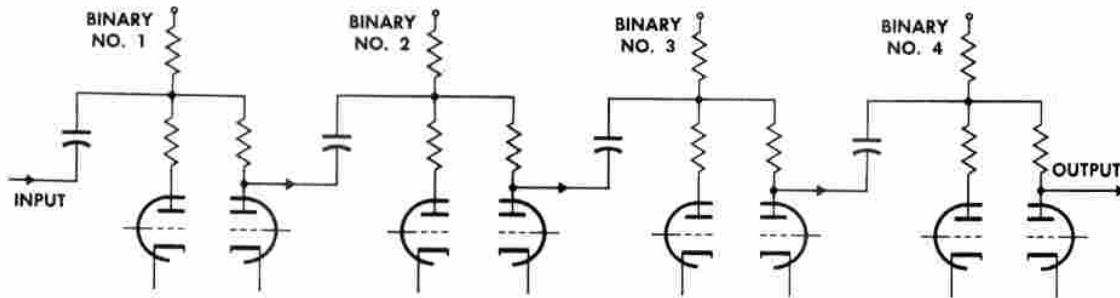

FIG. II-2 CASCADING BINARIES

102-4

Adapt the count to human habits

For displaying the count decimal operation is desired. The flip-flop chain has to be permuted to a scale of ten. This is done by adding 6 pulses internally which then cause one output pulse to be produced every 10 input pulses. Feedback circuits (Figure II-3) supply these extra pulses. On the count of 4 an extra pulse is fed from the third flip-flop to the second. This toggles the second flip-flop to its alternate conduction state. So the second flip-flop is forced into a condition which would normally request for two additional external pulses at the input.

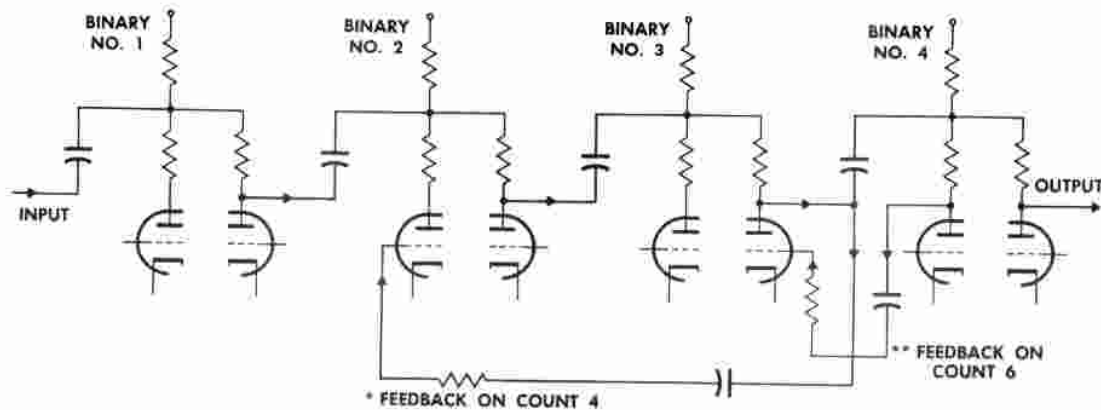

FIG. II-3 DECIMAL BINARIES

102-5

In a similar manner, on the count of 6, a feedback pulse from the fourth flip-flop is supplied to the third flip-flop providing its condition normal for having received four additional external pulses referred to the input.

In result the feedback forces the flip-flop chain to complete one cycle after 10 external input pulses.

An eye on the plates

Now that we have a decimal counting device the operator should be informed about the count. Therefore it is necessary to sense the conducting and non-conducting stages of all four flip-flops and use this data to indicate the appropriate number. A resistor matrix and tiny neon lamps connected like Figure II-5 are used to sample and display the count indication.

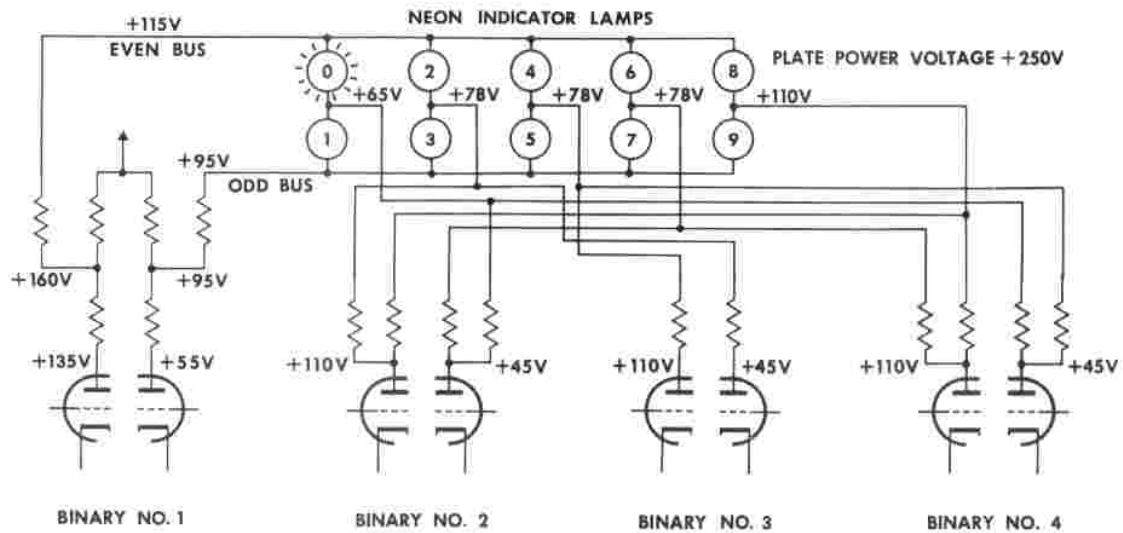

FIG. II-5
NEON LAMP RESISTOR MATRIX

102-15

For any one count, the conducting and non-conducting condition of the first flip-flop is determined by the count being odd or even. The plates of the first binary alternately drive the odd or even bus wires to a relatively high voltage.

One terminal of all lamps is connected to either the odd or even bus, while the other is connected via isolation resistors to two plates of the remaining second to fourth flip-flop. Three possible voltage levels exist: a high voltage if both plates are cut-off, a middle voltage if one plate is conducting and the other is cut-off and finally a low voltage if both plates are conducting.

Only the lamp connected between the odd or even bus which is at high voltage and the low voltage supplied by the combination of the connected pair of plates will fire. Voltage never entirely disappears from across the lamps, but only one lamp receives sufficient voltage difference to ionize and starts lighting. The lamps are placed behind a mask of numbers which results in an illuminated count.

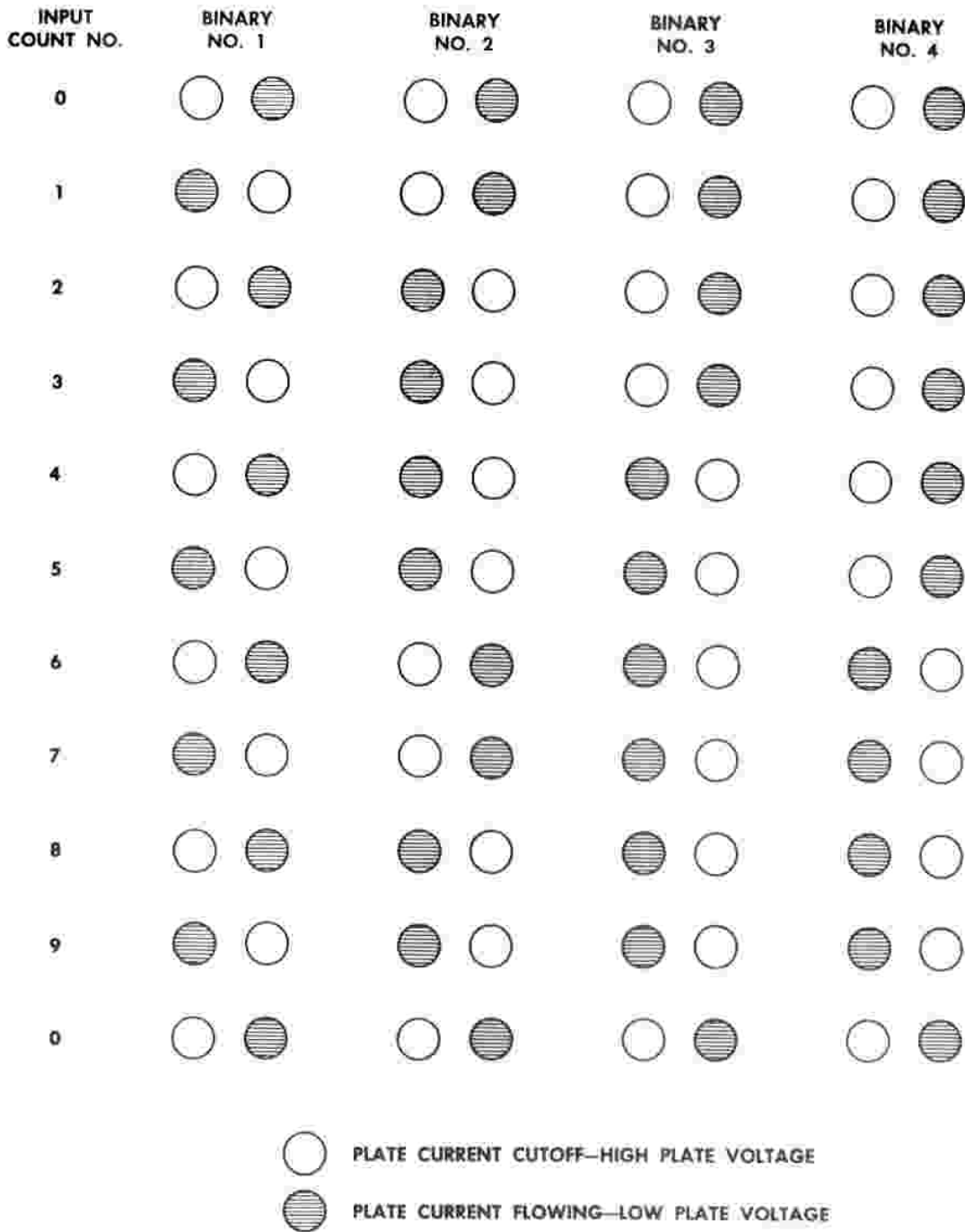

FIG. II-4 FIRING ORDER OF FOUR PERMUTED BINARIES

102-6

Adding a Nixie readout tube to the DCU is very easy. The nixie cathodes are connected to ground via light-sensitive resistors. Each resistor is optically coupled to only one neon lamp. So only the neon which fires controls the according number within the nixie.

Boosting performance

The basic DCU circuit described above works fine for input pulse repetition rates up to one megacycles. Above this rate these basic counters are no more triggered by the input spikes because of three reasons.

First the grids of the conducting stages have a large positive potential. The time to decrease this potential is high, as discharging the grid through capacitors has a rc time constant. To speed up the discharge and charge of the capacitors, diodes are used to clamp the grids to a potential just enough to ensure conducting and not more. Silicon diodes were used in Hewlett-Packard and CMC high-speed DCU's, Beckman/Berkeley used 6AL5 tubes.

Second an inherent delay between the tubes which are connected via the feedback path slow down the counting. Special circuit design of the feedback circuit gets better results.

At least the value of the plate resistors limit the charge and discharge time of the grid capacitors. Lowering the value increases the speed. However the available output amplitude is decreased as well. To encompass this the very first Hewlett-Packard high-speed counter (524A/B) the indication of the fastest decimals (units and tens counters) were done with meters, because the low output amplitude was too low for firing neons. The meter simply collects the plate currents. Different values for the plate resistors cause a weighted indication. It is in fact the same principle found in a Digital-to-Analog converter.